

EFX MK IV AUDIO CONTROLLER

OWNER'S MANUAL

Version 1.0

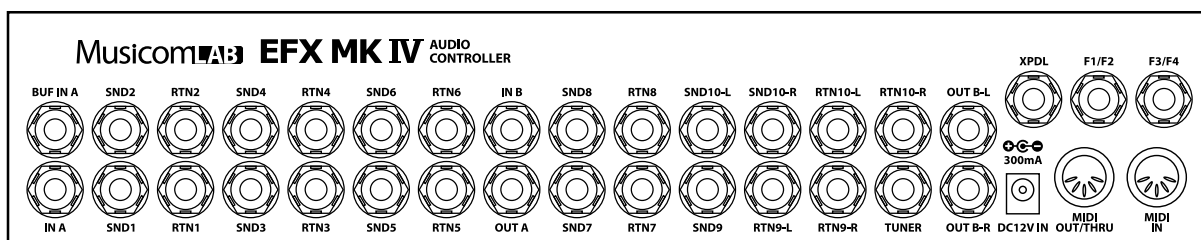
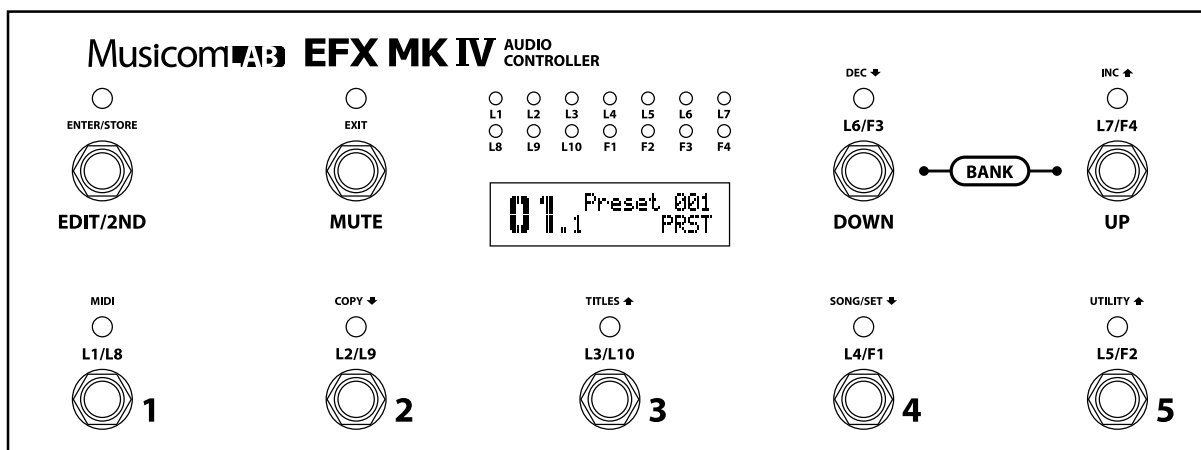

SAFETY PRECAUTIONS



WARNING

To reduce the risk of fire or electric shock, do not expose this appliance to rain or moisture.

CAUTION

To reduce the risk of fire or electric shock, do not remove screws. There are no user serviceable parts inside. Refer servicing to qualified service personnel

WARRANTY

Musicom Lab warrants this product against any defects that are due to defective parts or faulty workmanship for a period of two years from the date of original retail purchase. During this two years period, Musicom Lab will repair it without charge for parts or labor. However shipping charges to and from the repair location must be paid by the owner.

- This warranty does not include damage to the product resulting from accident or misuse.
- This warranty shall not apply to any goods that have been repaired or altered by anyone other than the manufacturer.

Contact the following for support and/or repair service.

Mail : Musicom Lab
15-4, Seooreung-ro 15-gil, Eunpyeong-gu, Seoul, 122-823, South Korea
Website : <http://www.musicomlab.com>
Email : support@musicomlab.com

Thank you for purchasing the Musicom Lab EFX MKIV Audio Controller. This Manual will introduce you to the EFX MKIV and its features. Make sure to keep this for future reference.

Table of Contents

1. Introduction	4
1.1 Main Features	4
1.2 Specifications	4
1.3 Block Diagram	5
1.4 Basic Connection	5
2. Fundamentals	6
2.1 Preset Mode	6
2.2 Song Mode	7
2.3 Set Mode	7
2.4 Instant Access Mode	8
2.3 Mute	8
3. EDIT Mode	9
4. MIDI Menu	10
4.1 Global Setting	10
4.1.1 MIDI OUT/THRU	11
4.1.2 Receive MIDI Channel	11
4.1.3 MIDI Program Change Channel	12
4.1.4 MIDI Control Change Channel/Number/Value	13
4.1.5 XPDL Global Setting	15
4.2 Preset Setting	17
4.2.1 MIDI Program Change Number	18
4.2.2 XPDL Preset Setting	19
5. COPY Menu	21
5.1 Preset Copy	21
5.2 Bank Copy	22
5.3 Song Copy	22
5.4 Set Copy	23
6. TITLES Menu	24
6.1 Preset Titles	24
6.2 Song Titles	25
7. SONG/SET Menu	26
7.1 Song Create/Edit	26
7.2 Set Create/Edit	27
8. UTILITY Menu	28
8.1 Operating Mode	29
8.2 Popping Reduction	29
8.3 Maximum Instant Access Page	30
8.4 Mute Position	30
8.5 Function Switch Type (Latched/Momentary)	31
8.6 DATA Dump	31
8.7 DATA Load	32
8.8 Factory Default Setting	32
9. Cables	33
9.1 XPDL	33
9.2 Function Switches	33

1. Introduction

Thank you for purchasing the Musicom Lab EFX MKIV Audio Controller.

The EFX MKIV Audio Controller is the ultimate floor-based switching system. It is a compact, easy to use, has 10 fully programmable loops, 4 function switches and a MIDI foot controller.

The EFX MKIV Audio Controller has 125 memory locations, configured as 25 banks of 5 presets, plus a global preset. It can transmit 6 MIDI Program Change messages on 6 MIDI channels and 28 MIDI Control Change messages on an appointed MIDI channel.

Also one continuous controller port(XPDL) is included and can be programmed with a designated MIDI channel and controller number.

The EFX MKIV Audio Controller has a low-noise, high quality buffer to prevent the loss of guitar signal. The input buffer can be bypassed for Hi-Z input pedals such as Fuzzes etc.

1.1 Main Features

- 10 audio loops arranged in a group of 6/4.
- Last 2 audio loops stereo capability.
- 4 function switches (latched or momentary).
- 5 presets per bank
- 5 presets per song
- 126 preset memory locations
- 25 banks of 5 presets, plus a Global Preset
- One expression pedal port (global or preset)
- Song and set modes
- Create up to 99 songs
- Organize the 99 Songs into 9 sets of 32 songs
- 2-line x 16-character LCD display with backlight
- Easily copy presets, banks, songs and sets
- Easily name presets and songs
- Bulk data dump and load capability
- Heavy-duty stomp switches and gold-plated relays

1.2 Specifications

- Buffer Input Impedance 1 M Ω
- Buffer Output Impedance 100 Ω
- Current Draw 300 mA (DC12V Center Negative)
- Dimensions 332(W) x 126(D) x 70(H) mm
13.1(W) x 5.0(D) x 2.8(H) inches
- Weight 1,320 g / 2.9 lbs

1.3 Block Diagram

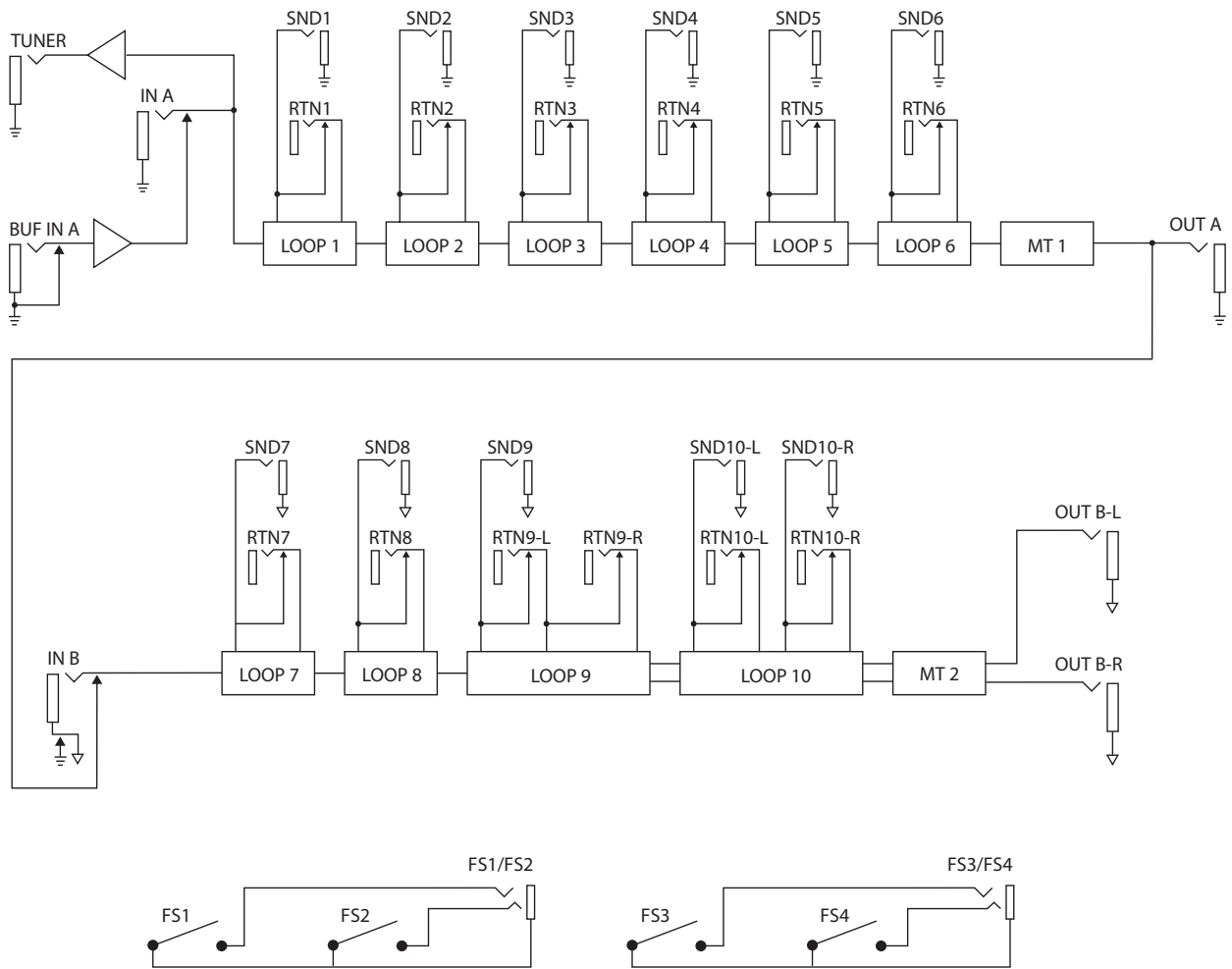

1.4 Basic Connection

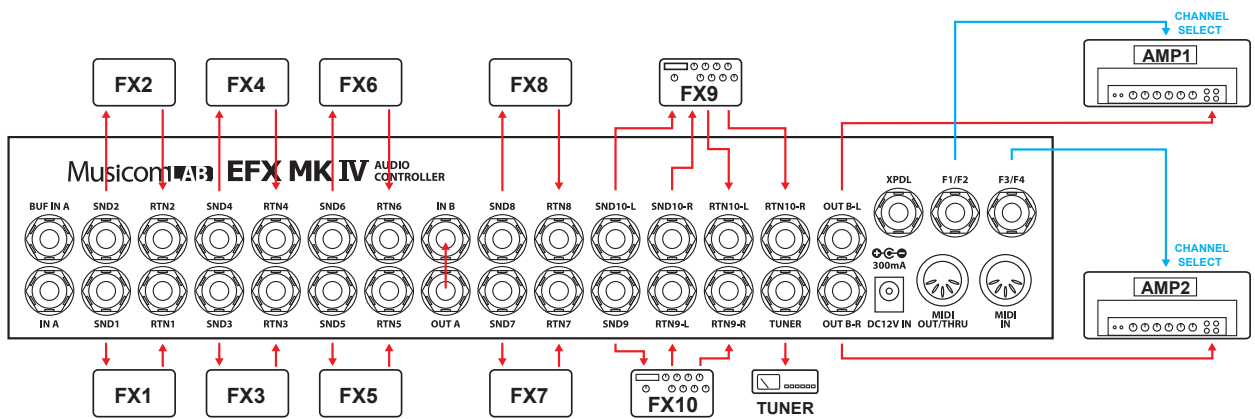

2. Fundamentals

The EFX MKIV has three different operating modes, plus Instant Access Mode and Edit Mode. The operating modes are Preset(PRST), Song(SONG) and Set(SET1-SET9)

The PRST Operating Mode allows the EFX MKIV to behave like a standard footcontroller with bank(25) of preset(5) plus a Global Preset.

The Song Operating Mode allows access to the EFX MKIV's 99 songs. Songs are basically a custom bank of the EFX MKIV's regular (banked) presets, arranged so that all the presets necessary during the performance of a song are available in one bank (conveniently called a song).

The SET0 - SET9 Operating Mode allows up to 32 of the EFX MKIV's 99 songs to be arranged in any order to create a set. The EFX MKIV can support 9 different sets.

2.1 Preset Mode

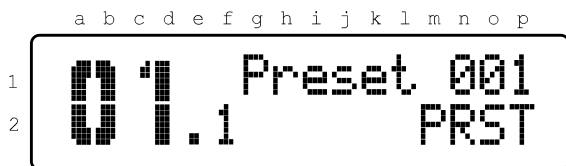

- Line 1 and 2 - a to d indicate a bank number.
- Line 1 - e to p indicate the preset titles.
- Line 2 - f indicates the preset (1 to 5) within the bank.

- ① Press/hold the **BANK UP** or **BANK DOWN** switch to scroll through the 25 available banks.
- ② The bank number will flash on the display.
- ③ The preset is selected via pressing any switches from **1** through **5**.
- ④ The bank number will stop flashing and the LED above the switch turn on.

For example: to select the second preset of bank 3, press the **BANK UP** or **BANK DOWN** switch until the bank number **3** is shown on the display. And then press the **2** switch.

The global preset is a preset with all the capabilities of preset 1 through 5, but is the same for all banks. Pressing the switch of a preset that is already on selects the global preset and will cause the LED above the switch to turn off.

2.2 Song Mode

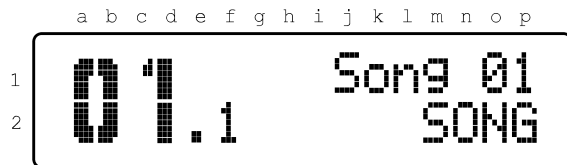

- Line 1 and 2 - a to d indicate a song number.
- Line 1 - e to p indicate the song titles.
- Line 2 - f indicates the preset (1 to 5) within the song.

- ① Press/hold the **BANK UP** or **BANK DOWN** switch to scroll through the 99 available songs.
- ② The song number will flash on the display.
- ③ The preset is selected via pressing any switches from **1** through **5**.
- ④ The song number will stop flashing and the LED above the switch turn on.

For example: to select the second preset of song 3, press the **BANK UP** or **BANK DOWN** switch until the song number **3** is shown on the display. And then press the **2** switch.

The global preset is a preset with all the capabilities of preset 1 through 5, but is the same for all songs. Pressing the switch of a preset that is already on selects the global preset and will cause the LED above the switch to turn off.

2.3 Set Mode

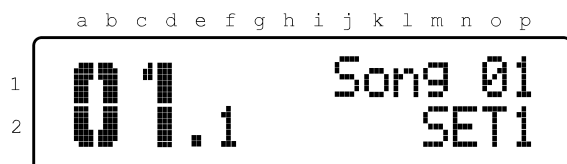

- Line 1 and 2 - a to d indicate a song number.
- Line 1 - e to p indicate the song titles.
- Line 2 - f indicates the preset (1 to 5) within the song.
- Line 2 - p indicates the current set mode (1 to 9).

- ① Press/hold the **BANK UP** or **BANK DOWN** switch to scroll through the 32 available songs.
- ② The song number will flash on the display.
- ③ The preset is selected via pressing any switches from **1** through **5**.
- ④ The song number will stop flashing and the LED above the switch turn on.

For example: to select the second preset of song 3, press the **BANK UP** or **BANK DOWN** switch until the song number **3** is shown on the display. And then press the **2** switch.

The global preset is a preset with all the capabilities of preset 1 through 5, but is the same for all songs. Pressing the switch of a preset that is already on selects the global preset and will cause the LED above the switch to turn off.

2.4 Instant Access Mode

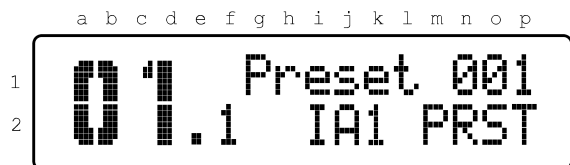

- Line 1 and 2 - a to d indicate a bank or song number.
- Line 1 - e to p indicate the preset or song titles.
- Line 2 - f indicates the preset (1 to 5) within the bank or song.
- Line 2 - k indicates the instant access page (1 to 4).
- Line 2 - m to p indicate the current operating mode (PRST, SONG or SET1 to SET9).

- ① Select the preset to be programmed in the Preset, Song or Set Mode.
 - ② Press the **EDIT/2ND** switch to enter the Instant Access Mode.
The 7 LEDs above the **1 ~ 5**, **BANK DOWN** and **BANK UP** switches will indicate the corresponding Loop1 ~ Loop7 as on or off.
 - ③ Press the **1** through **BANK UP** switches to turn the corresponding Loop1 ~ Loop7 on or off.
The corresponding LEDs will go on or off.
 - ④ Press the **EDIT/2ND** switch.
The 7 LEDs above the **1 ~ 5**, **BANK DOWN** and **BANK UP** switches will indicate the corresponding Loop8 ~ Loop10 and Function Switch1 ~ Function Switch4 as on or off.
 - ⑤ Press the **1** through **BANK UP** switches to turn the corresponding Loop8 ~ Loop10 and Function Switch1 ~ Function Switch4 on or off. The corresponding LEDs will go on or off.
 - ⑥ Press the **EDIT/2ND** switch.
The 7 LEDs above the **1 ~ 5**, **BANK DOWN** and **BANK UP** switches will indicate the corresponding CC15 ~ CC21 as on or off.
 - ⑦ Press the **1** through **BANK UP** switches to turn the corresponding CC15 ~ CC21 on or off.
The corresponding LEDs will go on or off.
 - ⑧ Press the **EDIT/2ND** switch.
The 7 LEDs above the **1 ~ 5**, **BANK DOWN** and **BANK UP** switches will indicate the corresponding CC22 ~ CC28 as on or off.
 - ⑨ Press the **1** through **BANK UP** switches to turn the corresponding CC22 ~ CC28 on or off.
The corresponding LEDs will go on or off.
 - ⑩ Press & hold the **EDIT/2ND** switch for 1 second to store the edit and return to Preset, Song or Set Mode.
For the other side, press & hold the **EDIT/2ND** switch and quickly press the **1** switch to return to Preset, Song or Set Mode without storing the edit.
- Max IA Page can be used to prevent access higher-numbered IA pages. Refer to the Maximum Instant Access Page on the page 30.

2.5 Mute

Press the **MUTE** switch to mute the guitar signal. When muted, the **MUTE** LED turns on.
Press the **MUTE** switch to cancel the mute function.

The mute position (MT1 or MT2) to be linked with this switch can be selected in UTILITY menu.
Refer to the Block Diagram on the page 5 and the Mute Position on the page 30.

3. EDIT Mode

The MIDI Menu provides access to the MIDI features of the EFX MKIV. To enter the Edit Mode, press and hold the **EDIT/2ND** switch for 1 second. The **MUTE** LED and the **1** to **5** LED's will start flashing. The display will show (the following Edit Menu).

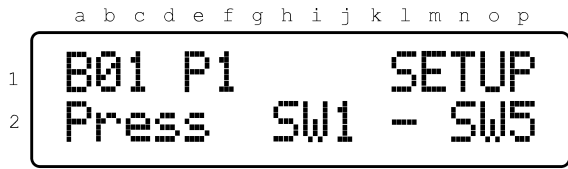

- Press the **MIDI (1)** switch to enter the MIDI Menu.
- Press the **COPY (2)** switch to enter the Copy Menu.
- Press the **TITLES (3)** switch to enter the Titles Menu.
- Press the **SONG/SET (4)** switch to enter the SongSet Menu.
- Press the **UTILITY (5)** switch to enter the Utility Menu.
- Press the **EXIT (MUTE)** switch to exit the Edit Mode.

4. MIDI Menu

The MIDI Menu provides access to the MIDI features of the EFX MKIV.

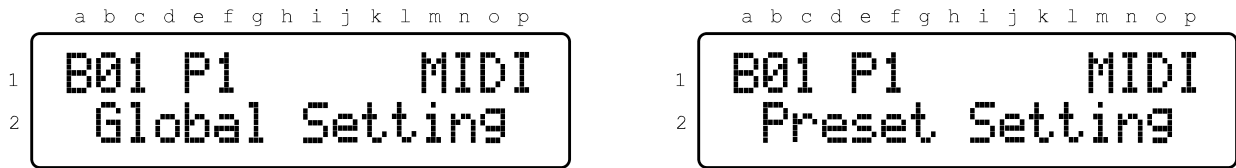

To switch/toggle the Global Setting and Preset Setting, press the **DEC↓(DOWN)** or **INC↑(UP)** switch. And press **ENTER(EDIT/2ND)** switch.

4.1 Global Setting

The Global Setting Menu allows defining global parameters such as ; the MIDI channel that the EFX MKIV will respond to incoming MIDI messages on, the MIDI program/control change channel and control number/value that the EFX MKIV will transmit, and expression pedal port control change setting.

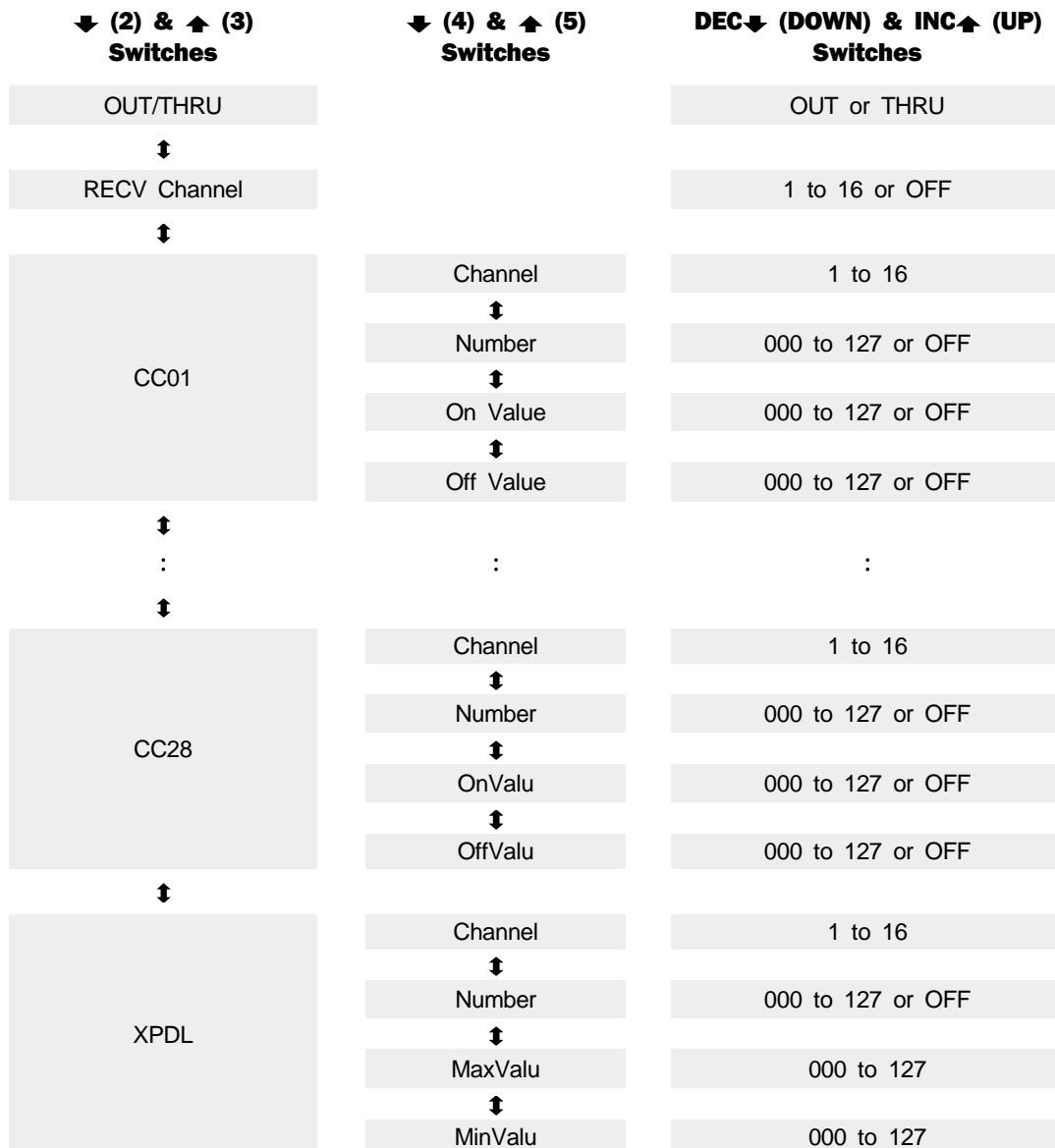

4.1.1 MIDI OUT/THRU

The MIDI OUT/THRU connector of the EFX MKIV functions as a MIDI OUT or MIDI THRU. When MIDI OUT operation is selected, MIDI data in the EFX MKIV are transmitted via the MIDI OUT connector. When MIDI THRU operation is selected, received MIDI data via the MIDI IN connector is retransmitted via the MIDI OUT connector. In this case, MIDI data in the EFX MKIV are not transmitted.



- Line 2 - l to p on the display indicate the MIDI OUT or MIDI THRU(OUT/THRU).

- ↓ (2) & ↑ (3)** Press to advance to the previous/next Global Setting menu.
- DEC↓ (DOWN) & INC↑ (UP)** Press to switch/toggle the MIDI OUT and MIDI THRU.
- ENTER/STORE (EDIT/2ND)** Press to store any changes made while in this sub-menu.
- EXIT (MUTE)** Press to return to the MIDI Menu.

4.1.2 Receive MIDI Channel

The EFX MKIV can receive the MIDI program change message. The receive MIDI channel can be set to any individual channel from 1 to through 16, or reception can be turned off.



- Line 2 - n to p on the display indicate the MIDI program change channel (01 to 16 or OFF) that the EFX MKIV will receive.

- ↓ (2) & ↑ (3)** Press and hold to advance to the previous/next Global Setting menu.
- DEC↓ (DOWN) & INC↑ (UP)** Press and hold to move/scroll through the 16 MIDI channel (01 to 16 or OFF).
- ENTER/STORE (EDIT/2ND)** Press to store any changes made while in this sub-menu.
- EXIT (MUTE)** Press to return to the MIDI Menu.

4.1.3 MIDI Program Change Channel

The EFX MKIV can transmit 6 MIDI program change messages (PC1 to PC6). Six MIDI program change messages are transmitted when an EFX MKIV preset is recalled to aid in selecting the desired preset on an external MIDI device. This sub-menu allows for the assignment of MIDI program change channels.

a b c d e f g h i j k l m n o p

1	B01	P1	MIDI
2	PC1	Channel	01

- Line 2 - c indicates the MIDI program change (1 to 6).
- Line 2 - o and p indicate the MIDI program change channel (01 to 16) that the EFX MKIV will transmit.

↓ (2) & ↑ (3)

Press and hold to advance to the previous/next Global Setting menu.

DEC↓ (DOWN) & INC↑ (UP)

Press and hold to move/scroll through the 16 MIDI channel (01 to 16).

ENTER/STORE (EDIT/2ND)

Press to store any changes made while in this sub-menu.

EXIT (MUTE)

Press to return to the MIDI Menu.

4.1.4 MIDI Control Change Channel/Number/Value

The EFX MKIV can transmit up to 28 MIDI control change messages (CC01 to CC28). This sub-menu allows for the assignment of MIDI control changes.

a b c d e f g h i j k l m n o p
1 B01 P1 MIDI
2 CC01 Channel 01

- Line 2 - c and d indicate the MIDI control change (01 to 28).
- Line 2 - o and p indicate the MIDI control change channel (01 to 16).

Press the **▲ (5)** switch and the display will show.

a b c d e f g h i j k l m n o p
1 B01 P1 MIDI
2 CC01 Number OFF

- Line 2 - n to p indicate the MIDI control change number (000 to 127 or OFF).

Press the **▲ (5)** switch and the display will show.

a b c d e f g h i j k l m n o p
1 B01 P1 MIDI
2 CC01 OnValu 127

- Line 2 - n to p indicate the MIDI control change value (000 to 127 or OFF) when a instant access switch will be 'ON'.

Press the **▲ (5)** switch and the display will show.

a b c d e f g h i j k l m n o p
1 B01 P1 MIDI
2 CC01 OffValu 000

- Line 2 - n to p on the display indicate the MIDI control change value (000 to 127 or OFF) when a instant access switch will be 'OFF'.

↓ (2) & ↑ (3)

Press and hold to advance to the previous/next Global Setting menu.

↓ (4) & ↑ (5)

Press and hold to move/scroll the Channel/Number/OnValu/OffValu menu.

DEC↓ (DOWN) & INC↑ (UP)

Press and hold to move/scroll a MIDI control change channel/number/
on_value/off_value

- Channel : 01 to 16
- Number : 000 to 127 or OFF
- On Value : 000 to 127 or OFF
- Off Value : 000 to 127 or OFF

ENTER/STORE (EDIT/2ND)

Press to store any changes made while in this sub-menu.

EXIT (MUTE)

Press to return to the MIDI Menu.

4.1.5 XPDL Global Setting

This sub-menu allows assigning the global setting(MIDI control change channel, number, maximum value and minimum value) for the expression pedal port.

a b c d e f g h i j k l m n o p

1	B01 P1	MIDI
2	XPDL Channel	01

- Line 2 - o and p indicate the XPDL MIDI control change channel (01 to 16).

Press the **▲ (5)** switch and the display will show.

a b c d e f g h i j k l m n o p

1	B01 P1	MIDI
2	XPDL Number	OFF

- Line 2 - n to p indicate the XPDL MIDI control change number (000 to 127 or OFF).

Press the **▲ (5)** switch and the display will show.

a b c d e f g h i j k l m n o p

1	B01 P1	MIDI
2	XPDL MaxValu	127

- Line 2 - n to p indicate the highest XPDL MIDI control change value (000 to 127) that the expression pedal port can transmit when its pedal is moved.

Press the **▲ (5)** switch and the display will show.

a b c d e f g h i j k l m n o p

1	B01 P1	MIDI
2	XPDL MinValu	000

- Line 2 - n to p indicate the lowest XPDL MIDI control change value (000 to 127) that the expression pedal port can transmit when its pedal is moved.

↓ (2) & ↑ (3)

Press and hold to advance to the previous/next Global Setting menu.

↓ (4) & ↑ (5)

Press and hold to move/scroll the Channel/Number/MaxValu/MinValu menu.

DEC↓ (DOWN) & INC↑ (UP)

Press and hold to move/scroll a XPDL control change channel/number/values.

- Channel : 01 to 16
- Number : 000 to 127 or OFF
- Maximum Value : 000 to 127
- Minimum Value : 000 to 127

ENTER/STORE (EDIT/2ND)

Press to store any changes made while in this sub-menu.

EXIT (MUTE)

Press to return to the MIDI Menu.

4.2 Preset Setting

The sub-menu allows assigning 6 MIDI program change number and determining how the expression port will function when used function in the preset.

↓ (2) & ↑ (3) Switches	↓ (4) & ↑ (5) Switches	DEC↓ (DOWN) & INC↑ (UP) Switches
Move/scroll a preset	PC1 Number	001 to 128 or OFF
	↕	
	PC2 Number	001 to 128 or OFF
	↕	
	:	:
	↕	
	PC6 Number	001 to 128 or OFF
	↕	
	XPDL Select	Global or Preset
	↕	
	XPDL Channel	01 to 16
↕		
XPDL Number	000 to 127 or OFF	
↕		
XPDL MaxValu	000 to 127	
↕		
XPDL MinValu	000 to 127	
↕		
XPDL BegValu	000 to 127, OFF or PDL	

4.2.1 MIDI Program Change Number

The EFX MKIV can transmit 6 MIDI program change messages (PC1 to PC6). Six MIDI program change messages are transmitted when an EFX MKIV preset is recalled to aid in selecting the desired preset on an external MIDI device. This sub-menu allows for the assignment of MIDI program change numbers.

```
  a b c d e f g h i j k l m n o p
1  B01 P1          MIDI
2  PC1  Number  001
```

- Line 1 - b and c indicate the bank number (01 to 25) that the preset is located in.
- Line 1 - e indicates the preset (1 to 5 or 0 for the Global Preset) that is going to be created/modified.
- Line 2 - c indicates the MIDI program change (1 to 6).
- Line 2 - n to p indicate the MIDI program change number (001 to 128 or OFF) that the EFX MKIV will transmit.

Press the **▲ (5)** switch to assign the PC2 Number.

Press the **▲ (5)** switch to assign the PC3 Number.

Press the **▲ (5)** switch to assign the PC4 Number.

Press the **▲ (5)** switch to assign the PC5 Number.

Press the **▲ (5)** switch to assign the PC6 Number.

▼ (2) & ▲ (3)

Press and hold to move/scroll a bank/preset number.

▼ (4) & ▲ (5)

Press and hold to move/scroll the PC1 to PC6 or XPDL menu.

DEC▼ (DOWN) & INC▲ (UP)

Press and hold to move/scroll a MIDI program change number (000 to 127 or OFF).

ENTER/STORE (EDIT/2ND)

Press to store any changes made while in this sub-menu.

EXIT (MUTE)

Press to return to the MIDI Menu.

4.2.2 XPDL Preset Setting

The expression pedal port can be set to use its global setting or preset setting specific setting for MIDI control change channel, number, maximum, minimum and beginning values.

a b c d e f g h i j k l m n o p

1	B01 P1	MIDI
2	XPDL Select	GLOB

- Line 1 - b and c indicate the bank number (01 to 25) that the preset is located in.
- Line 1 - e indicates the preset (1 to 5 or 0 for the Global Preset) that is going to be created/modified.
- Line 2 - m to p indicate whether the XPDL is configured as Global (GLOB) or Preset (PRST).

Press the **▲ (5)** switch and the display will show.

a b c d e f g h i j k l m n o p

1	B01 P1	MIDI
2	XPDL Channel	01

- Line 2 - o and p indicate the XPDL MIDI control change channel (01 to 16).

Press the **▲ (5)** switch and the display will show.

a b c d e f g h i j k l m n o p

1	B01 P1	MIDI
2	XPDL Number	OFF

- Line 2 - n to p indicate the XPDL MIDI control change number (000 to 127 or OFF).

Press the **▲ (5)** switch and the display will show.

a b c d e f g h i j k l m n o p

1	B01 P1	MIDI
2	XPDL MaxValu	127

- Line 2 - n to p indicate the highest XPDL MIDI control change value (000 to 127) that the expression pedal port can transmit when its pedal is moved.

Press the **▲ (5)** switch and the display will show.

a b c d e f g h i j k l m n o p

1	B01 P1	MIDI
2	XPDL MinValu	000

- Line 2 - n to p indicate the lowest XPDL MIDI control change value (000 to 127) that the expression pedal port can transmit when its pedal is moved.

Press the **▲ (5)** switch and the display will show.



- Line 2 - n to p indicate the initial XPDL MIDI control change value (000 to 127, or OFF) that the expression pedal port will transmit when the preset is selected.

▼ (2) & ▲ (3)

Press and hold to advance to the previous/next Global Setting menu.

▼ (4) & ▲ (5)

Press and hold to move/scroll the Select/Channel/Number/MaxValu/MinValu/BegValu or PC1 to PC6.

DEC▼ (DOWN) & INC▲ (UP)

Press and hold to move/scroll a XPDL control change channel/number/values.

- Select : Global or Preset
- Channel : 01 to 16
- Number : 000 to 127 or OFF
- Maximum Value : 000 to 127
- Minimum Value : 000 to 127
- Beginning Value : 000 to 127 or OFF

ENTER/STORE (EDIT/2ND)

Press to store any changes made while in this sub-menu.

EXIT (MUTE)

Press to return to the MIDI Menu.

5. Copy Menu

The Copy Menu allows copying presets, banks, songs and sets from one location to another.

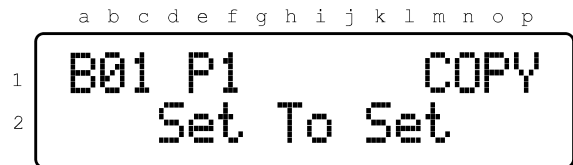
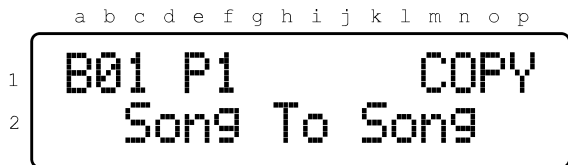
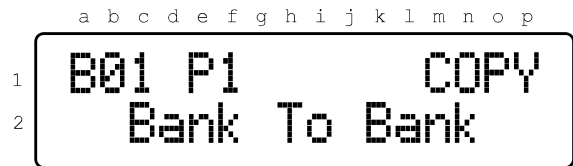
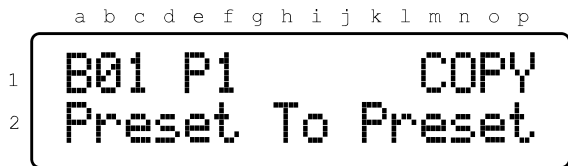

To move/scroll the Preset, Bank, Song or Set copy, press the **DEC↓(DOWN)** or **INC↑(UP)** switch. And press **ENTER(EDIT/2ND)** switch.

5.1 Preset Copy

The sub-menu allows for a single preset to be copied from on preset location to another.

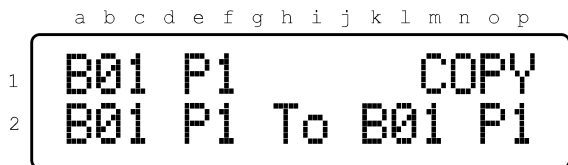

- Line 2 - b, c and f indicate the preset that is going to be copied.
- Line 2 - l, m and p indicate the destination preset location to copy to.

- ↓ (2) & ↑ (3)** Press and hold to move/scroll a preset that is going to be copied.
- DEC↓ (DOWN) & INC↑ (UP)** Press and hold to move/scroll a destination preset location to copy to.
- ENTER/STORE (EDIT/2ND)** Press to copy any changes made while in this sub-menu.
- EXIT (MUTE)** Press to return to the Copy Menu.

5.2 Bank Copy

The sub-menu allows for an entire bank of five presets to be copied from one bank location to another.

```
      a b c d e f g h i j k l m n o p
1  B01 P1          COPY
2  Bank01 To Bank01
```

- Line 2 - e and f indicate the bank (01 to 25) that is going to be copied.
- Line 2 - o and p indicate the destination bank location (01 to 25) to copy to.

- ↓ (2) & ↑ (3)** Press and hold to move/scroll a bank (01 to 25) that is going to be copied.
- DEC↓ (DOWN) & INC↑ (UP)** Press and hold to move/scroll a destination bank location (01 to 25) to copy to.
- ENTER/STORE (EDIT/2ND)** Press to copy any changes made while in this sub-menu.
- EXIT (MUTE)** Press to return to the Copy Menu.

5.3 Song Copy

The sub-menu allows for a song to be copied from one song location to another. This sub-menu copies the presets and locations associated with the song to be copied.

```
      a b c d e f g h i j k l m n o p
1  B01 P1          COPY
2  Song901 To Song901
```

- Line 2 - e and f indicate the song (01 to 99) that is going to be copied.
- Line 2 - o and p indicate the destination song location (01 to 99) to copy to.

- ↓ (2) & ↑ (3)** Press and hold to move/scroll a song (01 to 99) that is going to be copied.
- DEC↓ (DOWN) & INC↑ (UP)** Press and hold to move/scroll a destination song location (01 to 99) to copy to.
- ENTER/STORE (EDIT/2ND)** Press to copy any changes made while in this sub-menu.
- EXIT (MUTE)** Press to return to the Copy Menu.

5.4 Set Copy

The sub-menu allows for an entire set to be copied from one set location to another. This sub-menu copies all of the songs and their order of an entire set (32 songs).

a b c d e f g h i j k l m n o p

1	B01 P1	COPY
2	Set 1 To	Set 1

- Line 2 - e indicates the set (1 to 9) that is going to be copied.
- Line 2 - p indicates the destination set location (1 to 9) to copy to.

↓ (2) & ↑ (3)

Press and hold to move/scroll a set (1 to 9) that is going to be copied.

DEC↓ (DOWN) & INC↑ (UP)

Press and hold to move/scroll a destination set location (1 to 9) to copy to.

ENTER/STORE (EDIT/2ND)

Press to copy any changes made while in this sub-menu.

EXIT (MUTE)

Press to return to the Copy Menu.

6. Titles Menu

The Titles Menu allows for custom titles to be entered for each all presets and songs. Each custom preset and song title can be up to 12 characters in length.

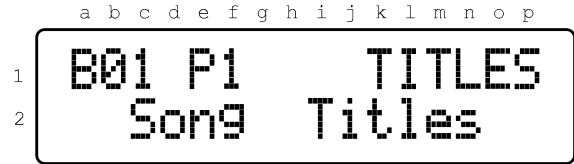

To switch/toggle the Preset Titles and Song Titles, press the **DEC↓(DOWN)** or **INC↑(UP)** switch. And press **ENTER(EDIT/2ND)** switch.

6.1 Preset Titles

The sub-menu allows for a custom preset title, up to 12 characters in length, to be created/modified for each of the all presets.



- Line 1 - b, c and f indicate the preset that is going to be created/modified.
- Line 2 - c to n indicate the preset title.

- | | |
|------------------------------------|--|
| ↓ (2) & ↑ (3) | Press and hold to move cursor when creating/modifying the preset title. |
| ↓ (4) & ↑ (5) | Press and hold to move/scroll through the available characters. |
| DEC↓ (DOWN) & INC↑ (UP) | Press and hold to move/scroll a preset that is going to be created/modified. |
| ENTER/STORE (EDIT/2ND) | Press to copy any changes made while in this sub-menu. |
| EXIT (MUTE) | Press to return to the Titles Menu. |

6.2 Song Titles

The sub-menu allows for a custom song title, up to 12 characters in length, to be created/modified for each of the all 99 songs.

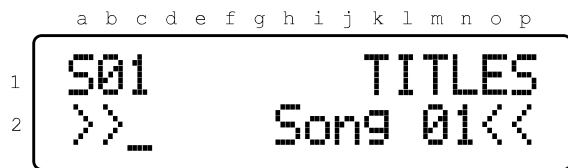

- Line 1 - b, c and f indicate the song that is going to be created/modified.
- Line 2 - c to n indicate the song title.

- | | |
|------------------------------------|--|
| ↓ (2) & ↑ (3) | Press and hold to move cursor when creating/modifying the song title. |
| ↓ (4) & ↑ (5) | Press and hold to move/scroll through the available characters. |
| DEC↓ (DOWN) & INC↑ (UP) | Press and hold to move/scroll a song that is going to be created/modified. |
| ENTER/STORE (EDIT/2ND) | Press to copy any changes made while in this sub-menu. |
| EXIT (MUTE) | Press to return to the Titles Menu. |

7. Song/Set Menu

The Song/Set Menu allows for regular presets to be organized in a custom bank to create a song (or custom bank of presets). Multiple songs can then be arranged in a bank order to create a set.

a b c d e f g h i j k l m n o p

1	B01 P1 SONG/SET
2	Song Create/Edit

a b c d e f g h i j k l m n o p

1	B01 P1 SONG/SET
2	Set Create/Edit

To switch/toggle the Song and Set Create/Edit, press the **DEC↓(DOWN)** or **INC↑(UP)** switch. And press **ENTER(EDIT/2ND)** switch.

7.1 Song Create/Edit

The sub-menu allows you to create a song (custom bank of presets) by assigning 5 presets. Each song contains 5 presets. The EFX MKIV can support 99 songs, each with a 12 character title, and they can be accessed via SONG and SET1 - SET9 Operating Modes.

a b c d e f g h i j k l m n o p

1	B01 P1 SONG/SET
2	Song01 P1=B01 P1

- Line 2 - e and f on the display indicate the song number (01 to 99) that is going to be created/edited.
- Line 2 - i on the display indicates the preset number (1 to 5) within the song.
- Line 2 - l and m on the display indicate the bank number (01 to 25) that the original preset is located in.
- Line 2 - p on the display indicates the preset number (1 to 5) in the above bank to be used in the song.

↓ (2) & ↑ (3)

Press and hold to move/scroll a song/preset number.

DEC↓ (DOWN) & INC↑ (UP)

Press and hold to move/scroll a bank/preset number.

ENTER/STORE (EDIT/2ND)

Press to copy any changes made while in this sub-menu.

EXIT (MUTE)

Press to return to the Song/Set Menu.

7.2 Set Create/Edit

The sub-menu allows songs to be arranged in a bank order to create set. The EFX MkIV can support 9 sets, they are accessed via SET1 - SET9 Operating Modes.

a b c d e f g h i j k l m n o p

1	B01 P1 SONG/SET
2	Set.1 Sn901=Sn901

- Line 2 - d indicates the set number (1 to 9) that is going to be created/edited.
- Line 2 - i and j indicate the song number (01 to 32) within the set.
- Line 2 - o and p indicate the original song number (01 to 99) to be used in the set.

↓ (2) & ↑ (3)

Press and hold to move/scroll a set number (1 to 9) that is going to be created/edited.

↓ (4) & ↑ (5)

Press and hold to move/scroll a song number (01 to 32) within the set.

DEC↓ (DOWN) & INC↑ (UP)

Press and hold to move/scroll a original number (01 to 99) to be used in the set.

ENTER/STORE (EDIT/2ND)

Press to copy any changes made while in this sub-menu.

EXIT (MUTE)

Press to return to the Song/Set Menu.

8. Utility Menu

The Song/Set Menu allows configuring the EFX MKIV's general functionality by selecting its operating mode, popping reduction, mute position, maximum instant access page and defining how the 4 function switches will function when used. Its sub-menu's also provide access to the data dump/load and factory default setting.

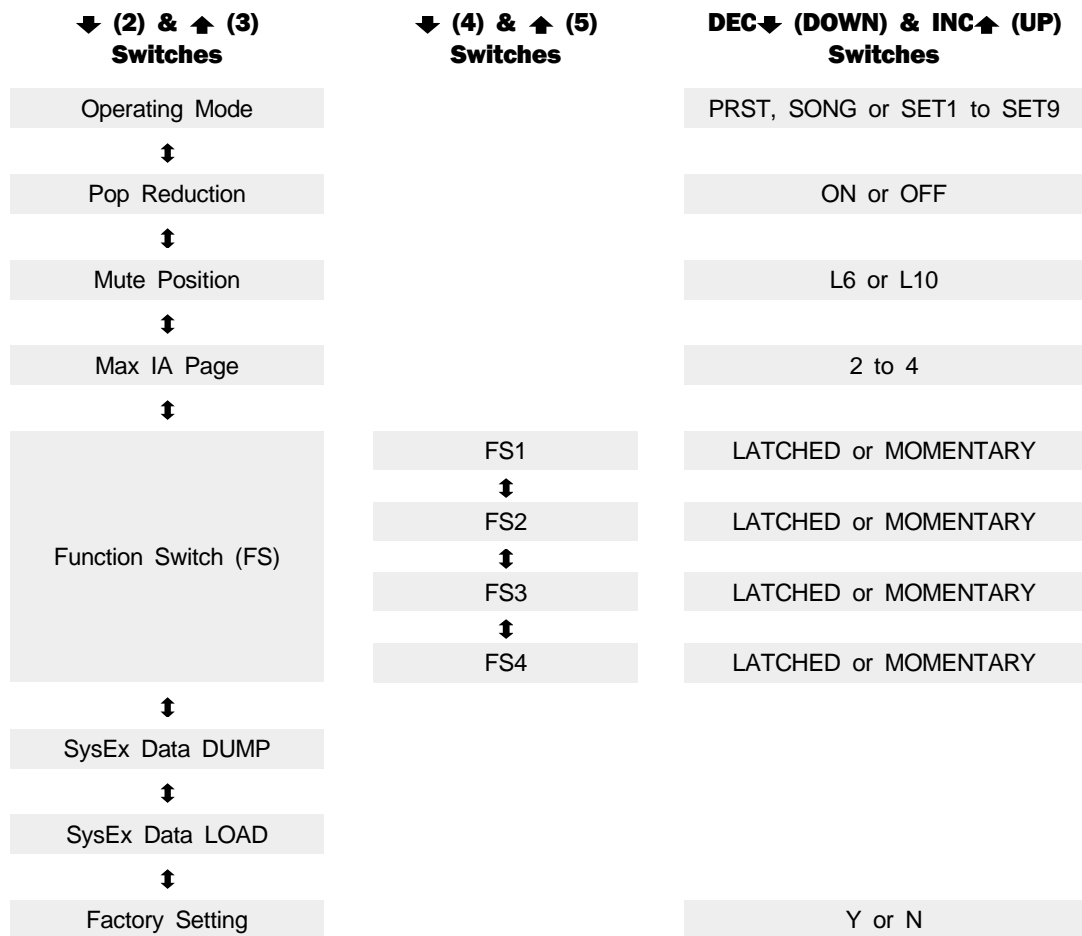

8.1 Operating Mode

The sub-menu allows determining the operating mode of the EFX MKIV.

```
a b c d e f g h i j k l m n o p
1 B01 P1 UTILITY
2 OperateMode PRST
```

- Line 2 - m to p indicate the operation mode (PRST, SONG, SET1 - SET9).

↓ (2) & ↑ (3)

Press to advance to the previous/next Utility menu.

DEC↓ (DOWN) & INC↑ (UP)

Press and hold to move/scroll through and select the desired operating mode.

ENTER/STORE (EDIT/2ND)

Press to copy any changes made while in this sub-menu.

EXIT (MUTE)

Press to return to the Edit Menu.

8.2 Popping Reduction

The EFX MKIV is based on relay switching. This method is utilized to route the audio signal with absolutely no tone coloration or degradation. The disadvantage of relays is that they can produce a slight popping noise when they switch on/off. The popping reduction control is excellent for reducing this popping noise.

The sub-menu allows determining the popping reduction control ON/OFF.

```
a b c d e f g h i j k l m n o p
1 B01 P1 UTILITY
2 PopReduction ON
```

- Line 2 - n to p indicate the popping reduction status (ON or OFF).

↓ (2) & ↑ (3)

Press to advance to the previous/next Utility menu.

DEC↓ (DOWN) & INC↑ (UP)

Press to switch/toggle the popping reduction control (ON or OFF).

ENTER/STORE (EDIT/2ND)

Press to copy any changes made while in this sub-menu.

EXIT (MUTE)

Press to return to the Edit Menu.

8.3 Maximum Instant Access Page

This sub-menu blocks to access to IA pages numbered above the Max IA Page. When set '2', this unit will transmit up to 14 MIDI control change messages (CC01 to CC14). When set '3', this unit will transmit up to 21 MIDI control change messages (CC01 to CC21). When set '4', this unit will transmit up to 28 MIDI control change messages (CC01 to CC28).

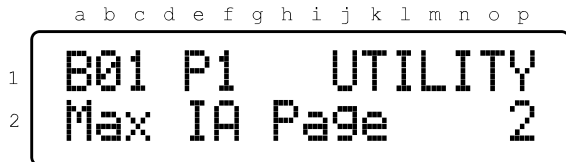

- Line 2 - p indicates the Maximum Instant Access Page (2 to 4).

- ↓ (2) & ↑ (3)** Press to advance to the previous/next Utility menu.
- DEC↓ (DOWN) & INC↑ (UP)** Press and hold to move/scroll through and select the desired Max IA page size.
- ENTER/STORE (EDIT/2ND)** Press to copy any changes made while in this sub-menu.
- EXIT (MUTE)** Press to return to the Edit Menu.

8.4 Mute Position

This sub-menu allow for the selection of the mute circuit (MT1 or MT2) activated by turning on the MUTE switch. Also the popping reduction control will work at this position. Refer to the Block Diagram on the page 5.

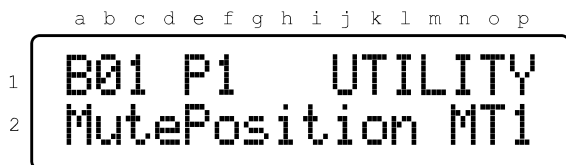

- Line 2 - n to p indicate the mute position (MT1 or MT2).

- ↓ (2) & ↑ (3)** Press to advance to the previous/next Utility menu.
- DEC↓ (DOWN) & INC↑ (UP)** Press to select the desired mute position (MT1 or MT2).
- ENTER/STORE (EDIT/2ND)** Press to copy any changes made while in this sub-menu.
- EXIT (MUTE)** Press to return to the Edit Menu.

8.5 Function Switch Type (Latched/Momentary)

The FS1 to FS4 will act as footswitches like those used for amp channel switching. The EFX MKIV supports both standard switch types, latched and momentary.

The sub-menu allows for the selection of the function switches type.

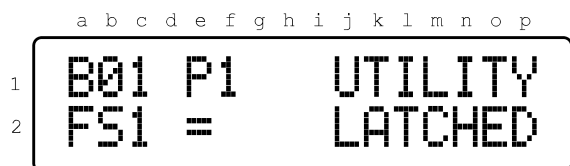

- Line 2 - c indicates a function switch (1 to 4) that is going to be edited.
- Line 2 - h to p indicate the function switch type (LATCHED or MOMENTARY).

↓ (2) & ↑ (3)

Press to advance to the previous/next Utility menu.

↓ (4) & ↑ (5)

Press and hold to move/scroll a the function switch (1 to 4) that is going to be edited.

DEC↓ (DOWN) & **INC**↑ (UP)

Press to switch/toggle the function switch type (LATCHED or MOMENTARY).

ENTER/STORE (EDIT/2ND)

Press to copy any changes made while in this sub-menu.

EXIT (MUTE)

Press to return to the Edit Menu.

8.6 DATA Dump

This sub-menu allows the EFX MKIV user data to be dumped (transmitted) to a computer or another EFX MKIV, via this unit's MIDI OUT/THRU jack. User data is dumped as a MIDI sysex (system exclusive) message.

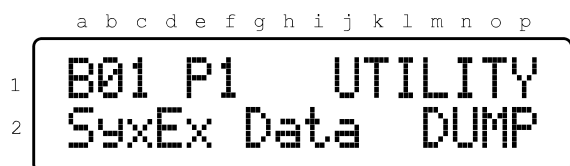

↓ (2) & ↑ (3)

Press to advance to the previous/next Utility menu.

ENTER/STORE (EDIT/2ND)

Press to start dumping.

EXIT (MUTE)

Press to return to the Edit Menu.

8.7 DATA Load

This sub-menu allows the EFX MKIV user data to be loaded (received) to a computer or another EFX MKIV , via this unit's MIDI IN jack. User data is loaded as a MIDI sysex (system exclusive) message.

a b c d e f g h i j k l m n o p

1	B01 P1	UTILITY
2	SyxEEx Data	LOAD

↓ (2) & ↑ (3)

Press to advance to the previous/next Utility menu.

EXIT (MUTE)

Press to return to the Edit Menu.

8.8 Factory Default Setting

This sub-menu allows erasing all user data from the internal EEPROM memory.

a b c d e f g h i j k l m n o p

1	B01 P1	UTILITY
2	FactorySetting	N

- Line 2 - p indicates the Yes or No (Y or N).

↓ (2) & ↑ (3)

Press to advance to the previous/next Utility menu.

DEC↓ (DOWN) & INC↑ (UP)

Press to switch/toggle the Yes or No (Y or N).

ENTER/STORE (EDIT/2ND)

Press to start the factory default setting.

EXIT (MUTE)

Press to return to the Edit Menu.

9. Cables

9.1 XPDL

XPDL & Volume Pedal

The cable required is a stereo (TRS) to two mono 1/4" phone plugs. Connect the tip(stereo plug) to the pedal input, ring to the pedal output and sleeve to ground on all 3 plugs.

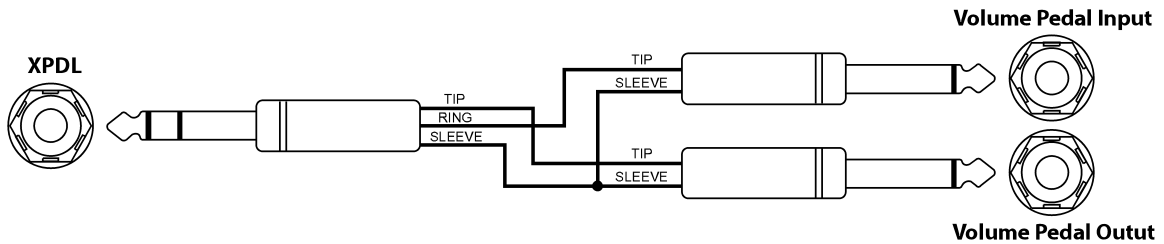

XPDL & Expression Pedal

The cable required is a stereo (TRS) to a stereo (TRS) 1/4" phone plugs.

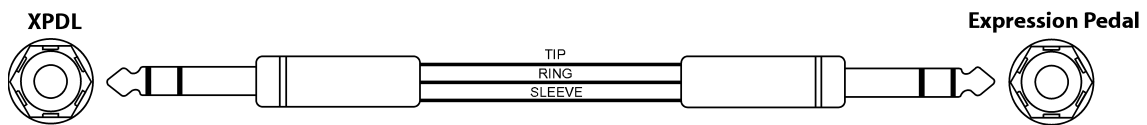

9.2 Functions Switches

The cable required is a stereo (TRS) to two mono 1/4" phone plugs. Connect the tip(stereo plug) to the pedal input, ring to the pedal output and sleeve to ground on all 3 plugs.

