

EFX MK III AUDIO CONTROLLER

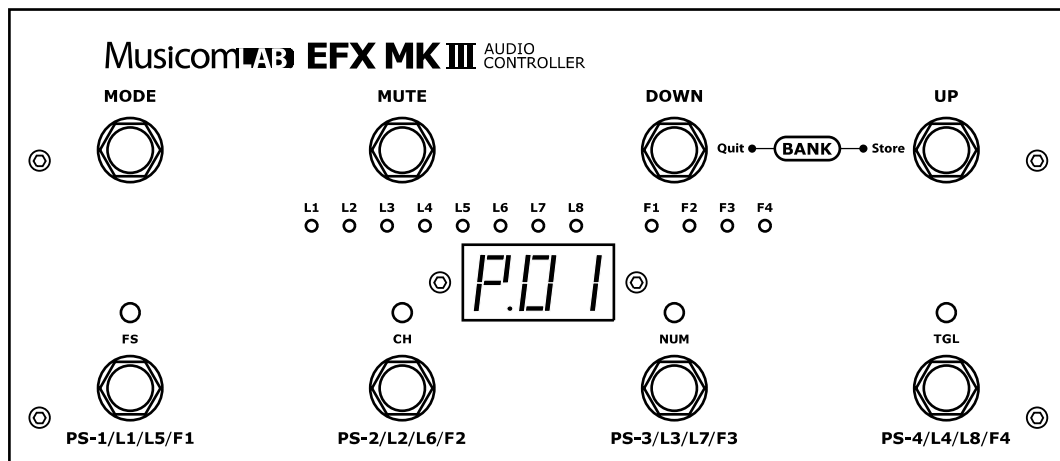

USER MANUAL (Ver 1.0)

Musicom AB

Thanks for your purchase of the Musicom Lab EFX MkII Audio Controller. This Manual will introduce you to the EFX MkII and its features. After reading this manual carefully keep it for future reference.

CONTENTS

1. Introduction	3
2. Basic Connection	4
3. Mode Description	5
3.1 Preset Mode	5
3.1.1 Mute	7
3.1.2 Input Buffer ON/OFF	7
3.1.3 Ground Lift ON/OFF	8
3.2 Instant Access Mode	5
3.3 Edit Mode	6
3.3.1 Editing MIDI Program Change	7
3.3.2 Editing MIDI Control Change	7
3.3.3 Editing XPD L Port	8
3.3.4 Popping Noise Reduction Control	11
4. Power Requirement	12
5. Initial Default Setting	12
6. Block Diagram	13
7. System Setting	14

1. Introduction

The EFX MkIII Audio Controller is the ultimate floor-based switching system.

It is a compact, easy to use, fully programmable 8 loops, 4 function switches and MIDI foot controller.

The EFX Mk III Audio Controller has 240 memory locations, configured as 60 banks of 4 presets, plus a global preset.

It can transmit 5 MIDI Program Change messages on 5 MIDI channels and 12 MIDI Control Change messages on an appointed MIDI channel.

Also one continuous controller port(XPDL) is included and can be programmed with designated MIDI channels and controller numbers.

The EFX Mk III Audio Controller has two low-noise, high quality buffers to prevent the loss of guitar signal. The input buffer can be bypassed for Hi-Z input pedals such as Fuzzes etc.

The EFX Mk II Audio Controller is made of high quality parts including heavy-duty stomp switches and gold-plated relays.

It is cased within a compact and rugged aluminium enclosure(11"W x 5.2"D x 1.7"FH x 2.2"RH).

Top Panel View

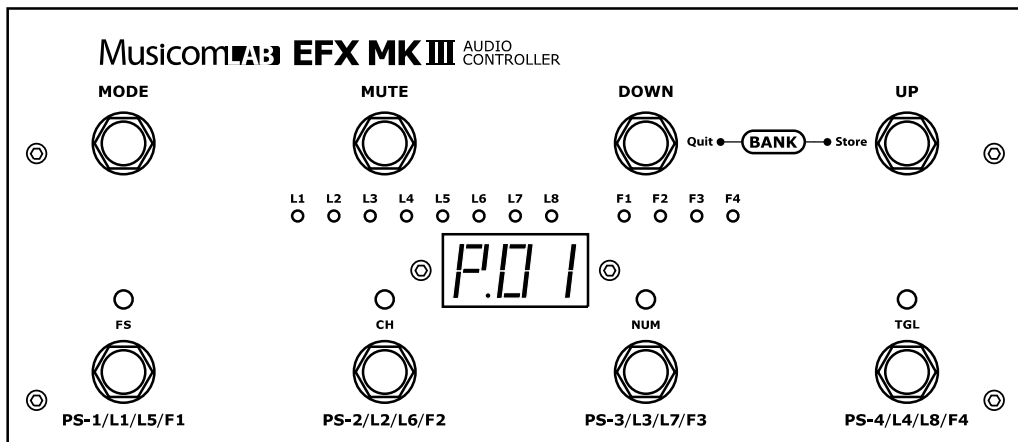

Rear Panel View

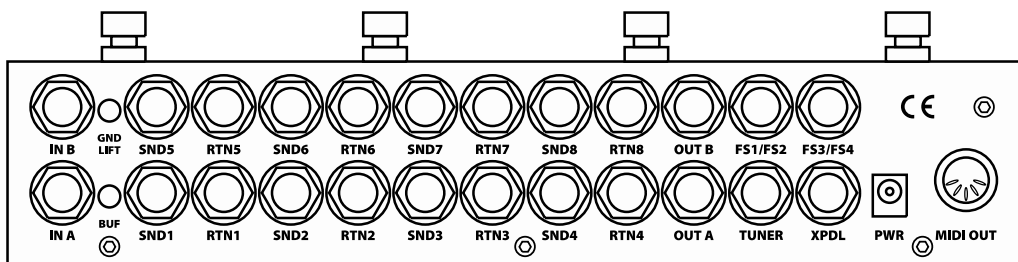

2. Basic Connection

- ① The loop send jacks(**SND1 ~ SND8**) and return jacks(**RTN1 ~ RTN8**) connect to the effects unit's inputs and outputs.

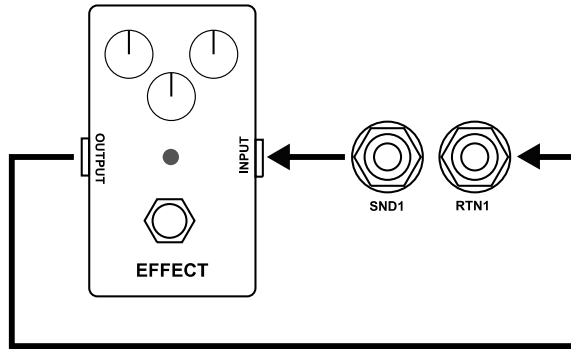

- ② The guitar connects to **IN A** jack, and amplifier input connects to **OUT B** jack. When there is the Hi-Z input pedal in the loop 1 ~ loop 4, the input buffer must be bypassed. Refer to page 5.
- ③ The tuner connects to the **TUNER** jack. Refer to page 5.

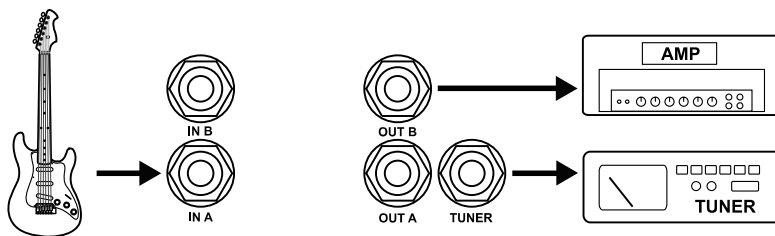

- ④ The channel control jacks connects to **FS1/FS2** and **FS3/FS4** jacks when function switches are used for remote amplifier channel switching.

For example:

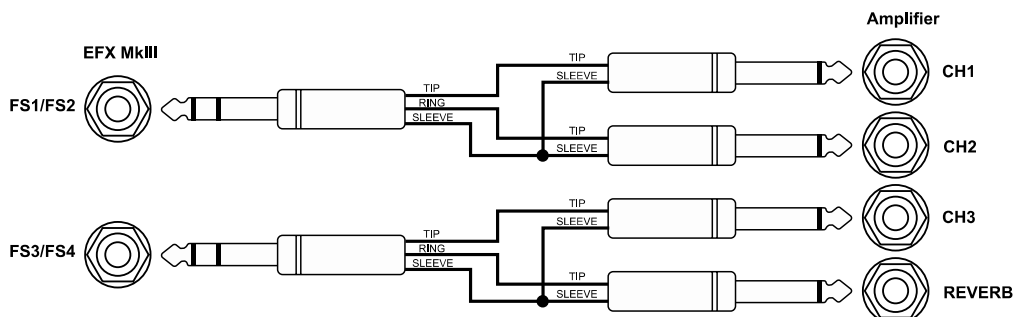

3. Mode Description

The EFX Mk III Audio Controller utilizes three modes of operation, Preset Mode, Instant Access Mode and Edit Mode.

On power-up, the display will show its firmware version, upon which bank 1 (**P.01** : Preset mode . Bank 1) and the global preset will be selected.

3.1 Preset Mode

The EFX Mk III Audio Controller has 241 presets, configured as 60 banks of 4 presets, plus a global preset which is common to all banks.

The Preset Mode is automatically selected when the power is initially turned on.

- ① Press/hold the **BANK UP** or **BANK DOWN** switches to scroll through the 60 available banks.
- ② The display will flash.
- ③ The preset is selected via pressing the **PS-1** through **PS-4** switches.
- ④ The display will stop flashing and the LED above the switch turns on.

For example, to select the second preset of the bank 3, press the **BANK UP** switch until the **P.03** is shown on the display. And then press the **PS-2** switch.

The global preset is a preset with all the capabilities of preset 1 through 4, but is the same for all banks. Pressing the switch of a preset that is already on selects the global preset and will cause the LED above the switch to turn off.

3.1.1 Mute

Press the **MUTE** switch to mute the output. When muted, the guitar signal flows into **TUNER** jacks and the three decimal points on the display will turn on and output signal will be mute.



Press the **MUTE** switch to cancel the mute function. Mute function is available in all mode.

3.1.2 Input Buffer On/Off

When you connect Hi-Z stompboxes like a Fuzz to in the Loop1 ~ Loop4, the input buffer must be bypassed.

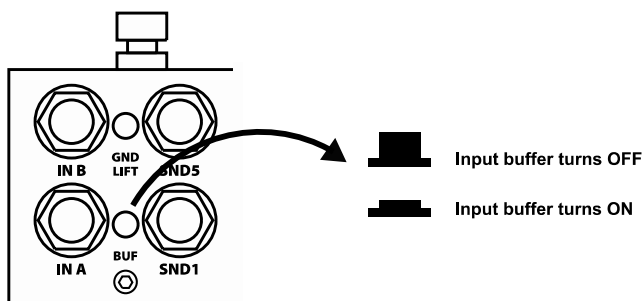

3.1.2 Ground Lift On/Off



The 8 loops of the EFX MkIII consist of 2 groups.

One is Group A from IN A to Out A, the other is Group B from IN B to OUT B.

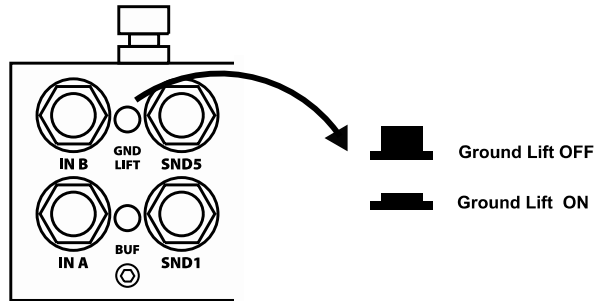
The ground Lift switch is useful to prevent ground loop hum/noise when connecting a musical instrument to **OUT A** and **IN B** jacks. Refer to page 13-16.



3.2 Instant Access Mode (Programming the Loops and Function Switches)

- ① Select the preset to be programmed in the Preset Mode.
- ② Press the **MODE** switch to enter the Instant Access Mode. The display will show:
And the 4 LEDs above **PS-1** ~ **PS-4** switches will indicate the corresponding Loop1 ~ Loop4 as on or off. 
- ③ Press the **PS-1** through **PS-4** switches to turn the corresponding Loop1 ~ Loop4 on or off. The corresponding LEDs will go on or off.
- ④ Press the **MODE** switch. The display will show:
And the 4 LEDs above **PS-1** ~ **PS-4** switches will indicate the corresponding Loop5 ~ Loop8 as on or off. 
- ⑤ Press the **PS-1** through **PS-4** switches to turn the corresponding Loop5 ~ Loop8 on or off. The corresponding LEDs will go on or off.
- ⑥ Press the **MODE** switch. The display will show:
And the 4 LEDs above **PS-1** ~ **PS-4** switches will indicate the corresponding Function Switch1 ~ Function Switch4 as on or off. 
- ⑦ Press the **PS-1** through **PS-4** switches to turn the corresponding Function Switch 1 ~ Function Switch 4 on or off. The corresponding LEDs will go on or off.
- ⑧ Press the **BANK UP** switch to store the edit and return to Preset Mode. The other side, press the **BANK DOWN** switch to return to preset mode without storing the edit.
- ⑨ Follow the same procedure ①~⑧ for any other presets you want to program the loops and function switches.

3.3 Edit Mode

The Edit Mode contains the utility functions. To enter the Edit Mode, you must be in the Preset Mode. Press/hold the **MODE** switch to enter the Edit Mode for 1 second. The display will show:



Press/hold the **PS-1** switch(FS, function select) to scroll the utility functions. Below is a list functions in the order that they are shown.

Function Select Order List

PC.1	sets 1st MIDI Program Change
PC.2	sets 2st MIDI Program Change
PC.3	sets 3st MIDI Program Change
PC.4	sets 4st MIDI Program Change
PC.5	sets 5st MIDI Program Change
LP.1	sets 1st MIDI Control Change for the Loop1 On/Off
LP.2	sets 2st MIDI Control Change for the Loop2 On/Off
LP.3	sets 3st MIDI Control Change for the Loop3 On/Off
LP.4	sets 4st MIDI Control Change for the Loop4 On/Off
LP.5	sets 5st MIDI Control Change for the Loop5 On/Off
LP.6	sets 6st MIDI Control Change for the Loop6 On/Off
LP.7	sets 7st MIDI Control Change for the Loop7 On/Off
LP.8	sets 8st MIDI Control Change for the Loop8 On/Off
FS.1	sets 9st MIDI Control Change for the Function Switch1 On/Off
FS.2	sets 10st MIDI Control Change for the Function Switch2 On/Off
FS.3	sets 11st MIDI Control Change for the Function Switch3 On/Off
FS.4	sets 12st MIDI Control Change for the Function Switch4 On/Off
EPL / ESW	sets MIDI Control Change for the continuous control port XPDL
Pr.0 ~ Pr.9	selects 10-stage popping noise reduction control

3.3.1 Editing MIDI Program Change

- ① Select the preset to be edited in the Preset Mode
- ② Press/hold the **MODE** switch to enter the Edit Mode for 1 second if you are in the Preset Mode. The **PC1** will be automatically selected and the display will show:
- ③ Press the **PS-2** switch(CH, channel) to set a **PC1** channel number. The display will show the current **PC1** channel.
- ④ Press/hold the **BANK UP** or **BANK DOWN** switches to select a channel from 1 through 16.
- ⑤ Press the **PS-2** switch to store a new **PC1** channel in memory. The display will show **str**(store) for a moment.

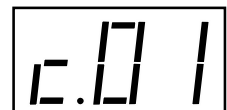
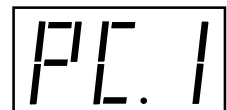

* The **PCs** channel is global (the same for all banks/presets). And you need not edit this for any other banks/presets if you have already done so. In this case, omit procedures ③~⑤.

⑥ Press the **PS-3** switch(NUM, number) to set a **PC1** number. The display will show the current **PC1** number.



⑦ Press/hold the **BANK UP** or **BANK DOWN** switches to select a **PC1** number from **001.** through **128.** or **not.**

⑧ Press the **PS-3** switch to store a new **PC1** number in memory. The display will show **str**(store) for a moment.

⑨ Press the **PS-1** switch(FS, function select) to set other **PCs** and follow the same procedure ③~⑧.

Note

* The **not.** means no Program Change is transmitted.

* The last decimal point on the display means that the display shows a Program Change number or controller number.

* For initial default Program Change channels and numbers setting are refer to page 12.

3.3.2 Editing MIDI Control Change

The MIDI Control Changes are transmitted via MIDI OUT jack when the assigned loops or function switches turn on or off. The **LP.1** is assigned the Loop1,, and the **FS.4** is assigned the Function Switch4.

* The Control Change channel and controller number are global (the same for all banks/presets). you need not edit these for any other banks/presets if you have already done so.

① Press/hold the **PS-1** switch(FS, function select) to edit the 1st Control Change until the **LP.1** is shown on the display if you are already in the Edit Mode.

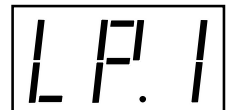

② Press the **PS-2** switch(CH, channel) to set a 1st Control Change channel. The display will show the current 1st Control Change channel.

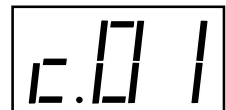

③ Press/hold the **BANK UP** or **BANK DOWN** switches to select a channel from 1 through 16.

④ Press the **PS-2** switch to store a new 1st Control Change channel in memory. The display will show **str**(store) for a moment.

⑤ Press the **PS-3** switch(NUM, number) to set 1st controller number. The display will show the current 1st Controller number.

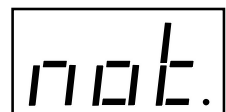

⑥ Press/hold the **BANK UP** or **BANK DOWN** switches to select a 1st controller number from **000.** through **127.** or **not.**

⑦ Press the **PS-3** switch to store a new 1st controller number in memory. The display will show **str**(store) for a moment.

⑧ The EFX MkIII has an additional reverse function which reverse the control value. Press the **PS-4** switch(TGL, toggle) to reverse 1st control value. The display will show the current 1st control value mode.



The table below shows the control value of the normal and reverse mode.

	Loop turns on	Loop turns off
<i>nor</i> (normal)	127 (0x7F)	0 (0x00)
<i>rEv</i> (reverse)	0 (0x00)	127 (0x7F)

The table below shows the contact of the Function Switch.

	Contact
<i>nor</i> (normal)	Normally - Open
<i>rEv</i> (reverse)	Normally - Closed

⑨ Press the **BANK UP** switch to toggle between normal and reverse. The display will show:

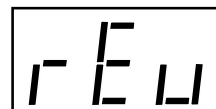

⑩ Press the **PS-4** switch to store the reverse function in memory. The display will show **str**(store) for a moment.

⑪ Follow the same procedure ①~⑩ to set from 2st MIDI Control Change through 12st MIDI Control Change.

Note

- * The *not*. means no Control Change is transmitted.
- * The *nor* means normal and the *rEv* means reverse.
- * The corresponding loop is always turned off when you set a controller number from **000**. through **127**.
- * The last decimal point on the display means that the display shows a Program Change number or controller number.
- * For initial default Control Change channels and controller numbers setting are refer to page 12.

3.3.3 Editing XPDL Port

The EFX Mk III contains a **XPDL** port for expression pedal input or external foot switch input. This can be used to alter parameters(via MIDI) in effects device that offer this capability.

The MIDI Control Change Value is transmitted corresponding to the position of expression pedal or external foot switch.

Any passive volume or expression pedal can be used. Recommended expression pedals are Boss FV500L/H and FV300L/H, external foot switches are Boss FS-5U and FS-5L.

- * The **EPL** or **ESW** channel and number are global (the same for all banks/presets). you need not edit these for any other banks/presets if you have already done so.

① Press/hold the **FS-1** switch(FS, function select) to edit the **EPL** or **ESW** for the **XPDL** port until the **EPL** or **ESW** is shown on the display if you are already in the Edit Mode.



The display shows the **EPL**(Expression Pedal) when the expression pedal is connect to the **XPDL** jack.

Otherwise, The display shows the **ESW**(External Foot Switch) when the external foot switch is connected

or a plug is not connected to the **XPDL** jack.

- ② Press the **PS-2** switch(CH, channel) to set a **EPL** or **ESW** channel. The display will show the **EPL** or **ESW** channel.
- ③ Press/hold the **BANK UP** or **BANK DOWN** switches to select a channel from 1 through 16.
- ④ Press the **PS-2** switch to store a new channel in memory. The display will show **str**(store) for a moment.
- ⑤ Press the **PS-3** switch(NUM, number) to set a **EPL** or **ESW** controller number. The display will show the current **EPL** or **ESW** controller number.
- ⑥ Press/hold the **BANK UP** or **BANK DOWN** switches to select a **EPL** or **ESW** controller number from **000.** through **127.** or **not.**
- ⑦ Press the **PS-3** switch to store a new **EPL** or **ESW** controller number in memory. The display will show **str**(store) for a moment.
- ⑧ The EFX MkIII has an additional reverse function which reverse the control value. Press the **PS-4** switch(TGL, toggle) to reverse a **EPL** or **ESW** control value. The display will show the current **EPL** or **ESW** control value mode.



The table below shows the control value of the normal and reverse mode.

	Expression Pedal (EPL)			External Foot switch (ESW)	
	Normal	Reverse		Normal	Reverse
Minimum Position	0 (0x00)	127 (0x7F)	Open	0 (0x00)	127 (0x7F)
⋮	⋮	⋮	Closed	127 (0x7F)	0 (0x00)
Maximum Position	127 (0x7F)	0 (0x00)			

- ⑨ Press the **BANK UP** switch to toggle between normal and reverse. The display will show:
- ⑩ Press the **PS-4** switch to store the reverse function in memory. The display will show **str**(store) for a moment.

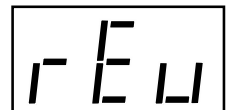

Cable Wiring for Expression Pedal

The cable required is a stereo (TRS) to two mono 1/4" phone plugs. Connect the tip(stereo plug) to the pedal input, ring to the pedal output and sleeve to ground on all 3 plugs.

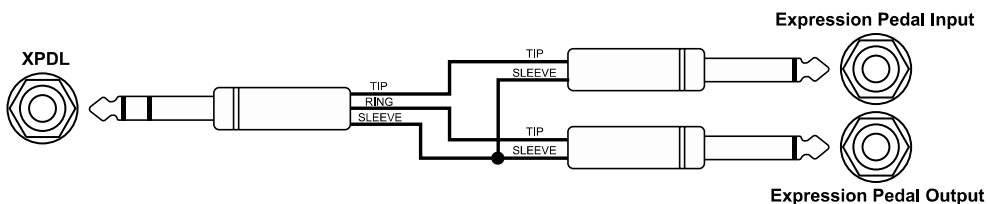

Cable Wiring for External Foot Switch

The cable required is a mono (TS) to a mono(TS) 1/4" phone plugs.

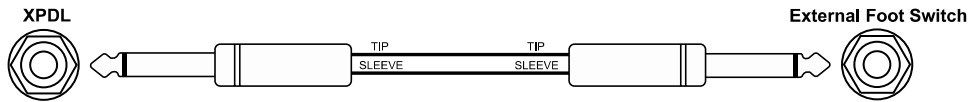

Note

- * The **not** means no Control Change is transmitted.
- * The last decimal point on the display means that the display shows a Program Change number or controller number.
- * For initial default Control Change channels and controller numbers setting are refer to page 12.
- * Connect a expression pedal or a external foot switch to the **XPDL** jack before the power applies to EFX MkIII Audio Controller.

3.3.4 Popping Noise Reduction Control

The EFX MkIII Audio Controller is based on relay switching. This method is utilized to route the audio signal with absolutely no tone coloration or degradation. But the disadvantage of relays is that they can produce a slight popping noise when they switch on/off. The 10-stage popping noise reduction control is excellent for reducing this popping noise by muting time control of audio signal and switching order when the relays switch on/off.

- * The popping noise reduction control is global (the same for all banks/presets). you need not edit this for any other banks/presets if you have already done so.

- ① Press/hold the **PS-1** switch(FS, function select) to set the popping noise reduction control until the **Pr.4** is shown on the display if you are already in the Edit Mode.
- ② Press/hold the **BANK UP** switch to set a popping noise reduction control from **Pr.0** through **Pr.9**.

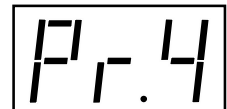

It will automatically be stored in memory when you return to Preset Mode.

Pr0 means the popping noise reduction control is not used.

⋮

Pr9 means the maximum of the popping noise reduction control.

Note

- * The initial default setting is **Pr.4**.

4. Power Requirements

The EFX Mk-II Audio Controller requires regulated 12VDC or 9VAC at approximately 240mA. The power jack is a standard 5.5mm/2.1mm barrel.

Also, the EFX MkIII can be powered from outputs 5 or 6 of the Voodoo Lab Pedal Power 2 Plus. You must set the corresponding DIP switch away from the normal position.

5. Initial Default Setting

The initial default setting for the EFX Mk II Audio Controller may be reset with the following procedure. This procedure will erase all user data from the EEPROM memory. Apply power while holding the **MODE** and **PS-1** switches down. The display will show:



The L1-L8 LEDs will turn on, at which point the two switches can be released.

When the initial default setting is successful, the EFX Mk II Audio Controller will automatically restart.

Initial Default MIDI Setting

Bank . Preset	PC1		PC2		PC3		PC4		PC5		CCs	
	CH	NUM	CH	NUM	CH	NUM	CH	NUM	CH	NUM	CH	NUM
Global		not		not		not		not		not		
1 . 1		1		not		not		not		not		
1 . 2		2		not		not		not		not		
1 . 3		3		not		not		not		not		
1 . 4		4		not		not		not		not		
⋮		⋮		⋮		⋮		⋮		⋮		
32 . 3	1	127	2	not	3	not	4	not	5	not	1	not
32 . 4		128		not		not		not		not		
33 . 1		not		not		not		not		not		
33 . 2		not		not		not		not		not		
⋮		⋮		⋮		⋮		⋮		⋮		
60 . 4		not		not		not		not		not		

6. Block Diagram

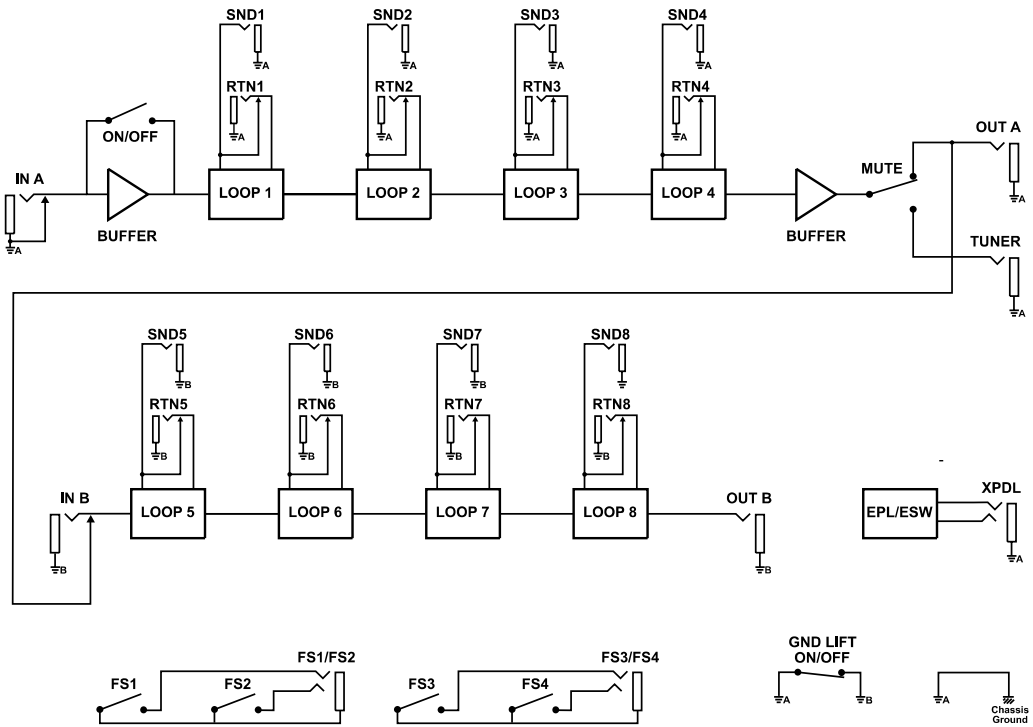

7. System Example

* Basic system

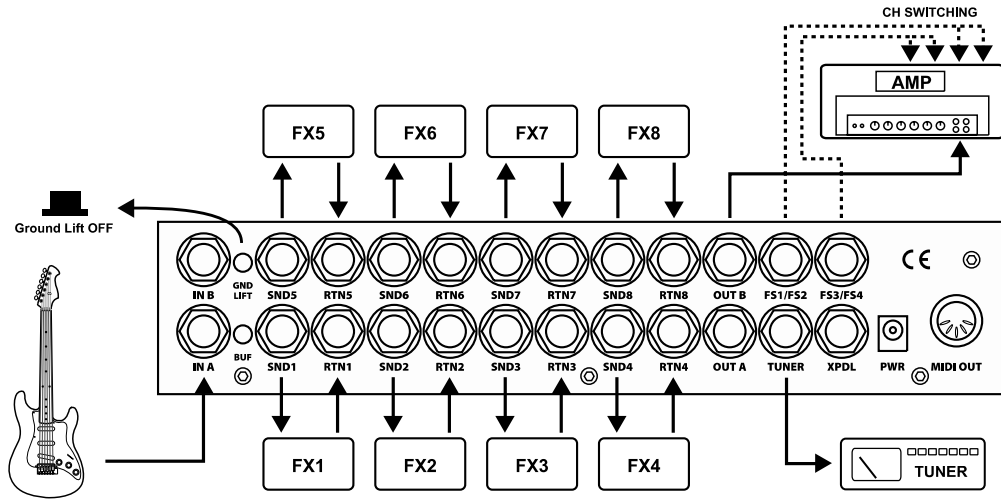

* Input switched between two guitars

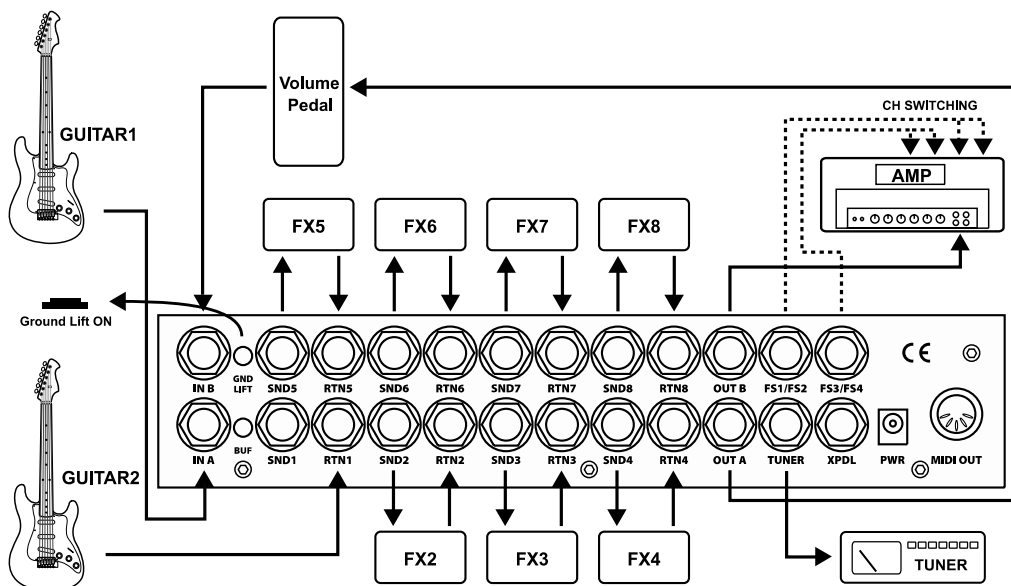

* System with output switchable to either of two amplifiers used

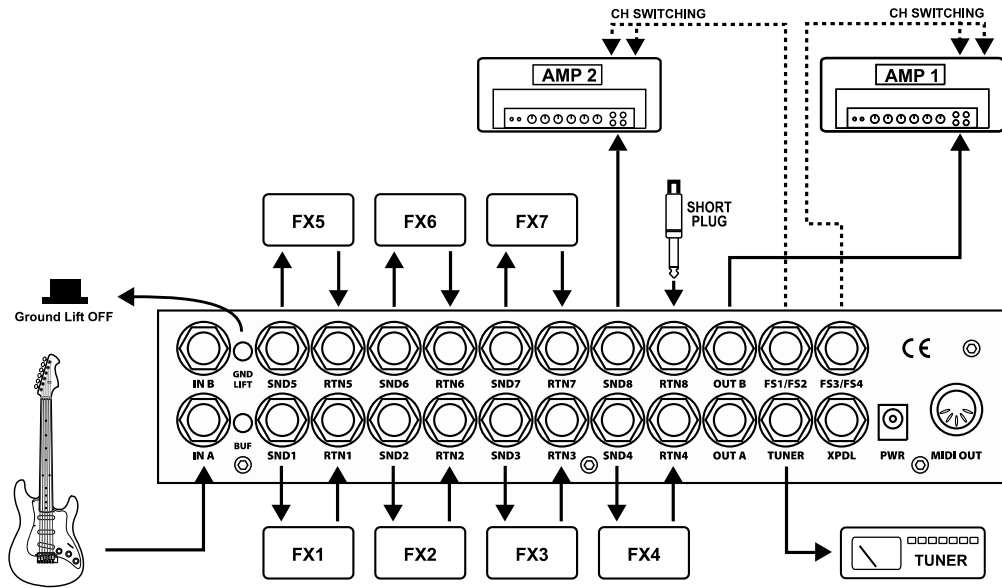

* System with output switchable to either or both of two amplifiers used

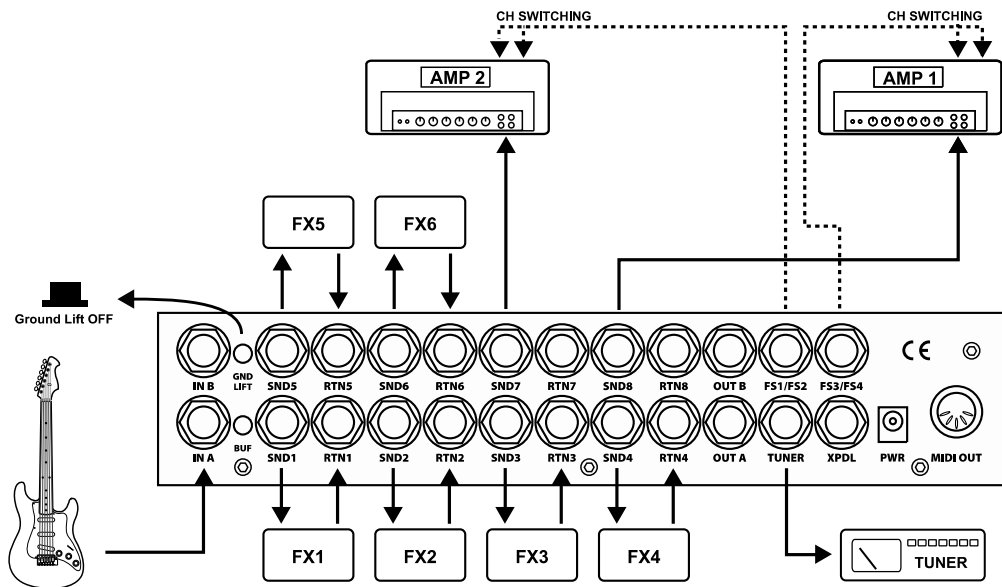

* Chorus / Delay patch change via MIDI PCs

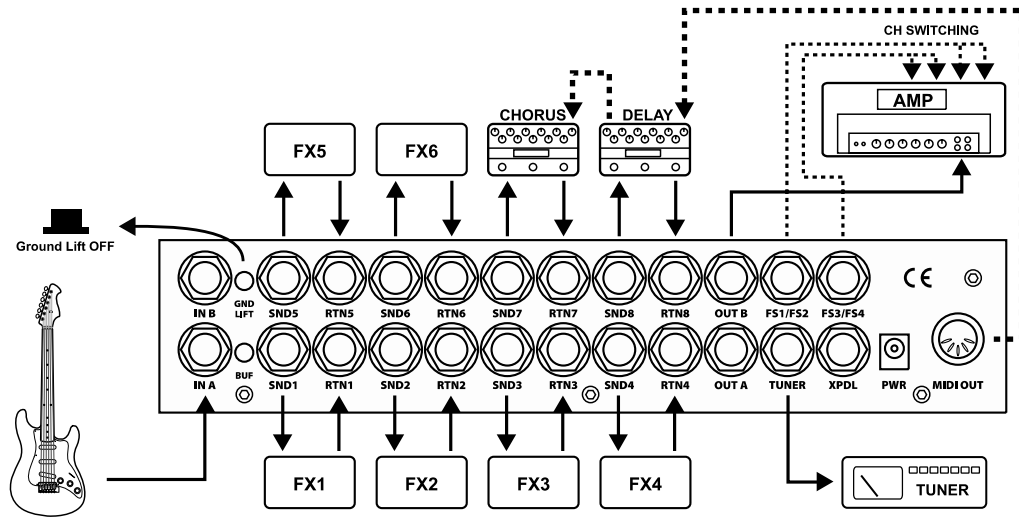

* Rack system with Mixer

